

## Research Article

# Axisymmetric Vibration of Piezo-Lemv Composite Hollow Multilayer Cylinder

**E. S. Nehru**

*Department of General Studies, Jubail University College, P.O. Box 10074, Jubail 31961, Saudi Arabia*

Correspondence should be addressed to E. S. Nehru, esnehr@yahoo.com

Received 4 September 2011; Accepted 22 November 2011

Academic Editor: Adolfo Ballester-Bolinches

Copyright © 2012 E. S. Nehru. This is an open access article distributed under the Creative Commons Attribution License, which permits unrestricted use, distribution, and reproduction in any medium, provided the original work is properly cited.

Axisymmetric vibration of an infinite piezolaminated multilayer hollow cylinder made of piezoelectric layers of 6 mm class and an isotropic LEMV (Linear Elastic Materials with Voids) layers is studied. The frequency equations are obtained for the traction free outer surface with continuity conditions at the interfaces. Numerical results are carried out for the inner, middle, and outer hollow piezoelectric layers bonded by LEMV (It is hypothetical material) layers and the dispersion curves are compared with that of a similar 3-layer model and of 3 and 5 layer models with inner, middle, and outer hollow piezoelectric layers bonded by CFRP (Carbon fiber reinforced plastics).

## 1. Introduction

Piezocomposite materials have drawn considerable attention in recent years due to their potential application in ultrasonic and underwater transducers [1, 2]. Piezocomposites have potential for higher electromechanical coupling coefficients, lower acoustic impedance, higher piezoelectric voltage constants, and higher hydrostatic coefficients compared to conventional dense materials. In addition, by changing the ceramic/polymer volume fractions, the material parameters of a composite transducer can be altered to meet specific requirements for different applications [3]. Piezocomposites exist in various connectivities [4], with 0–3 [5], 1–3 [6], 2–2 [7], and 3–3 [8] being the most common for transducer applications.

The 1–3 piezocomposite system has been studied extensively and various modelling and experimental studies have been reported in the literature [9, 10]. Although, 1–3 composites are highly useful for transducer applications, their production can be relatively expensive [6]. The 3–3 piezocomposites are a possible alternative, with comparable material properties and a relatively simple method of synthesis [8, 11]. Experimental studies on 3–3 piezoelectric structures indicate that they have a higher hydrostatic figure of merit [12–14] compared to dense PZT hydrophones of similar design [8, 15, 16].

Multilayer piezoelectric structures are widely applied as a smart structure in precise apparatus.

Multilayer piezoelectric ceramic displacement actuator is a typical smart composite structure and has wide application in precise apparatus [17, 18].

Damage detection and vibration control of a new smart board designed by mounting piezoelectric fibers with metal cores on the surface of a CFRP composite were studied by Takagi et al. [19]. Tanimoto [20] has discussed the passive damping of CFRP cantilever beam, surface bonded by piezoelectric ceramics.

The exact frequency equation for piezoelectric circular cylindrical shell of hexagonal (6 mm) class was first obtained by Paul [21]. Paul and Nelson [22–25] have studied free vibration of piezocomposite plate and cylinders by embedding LEMV-layer between piezoelectric layers.

A general frequency equation is derived for axisymmetric vibration of an infinite laminated hollow cylinder. Both the inner and outer surfaces are traction free and connected with electrodes and are shorted. Numerical calculations are carried out for PZT4/LEMV/PZT4/LEMV/PZT4. The attenuation effect is considered through the imaginary part of the dimensionless complex frequency Sinha et al. [26].

## 2. Fundamental Equations and Method of Analysis

The cylindrical polar coordinate system  $(r, \theta, z)$  is used for composite piezoelectric cylinder. The superscripts  $\ell = 1, 3, 5$  are taken to denote the inner solid, middle, and outer hollow piezoelectric cylinders, respectively.

The governing equations for hexagonal (6 mm) class are Paul and Nelson (1996) [24].

$$\begin{aligned} c_{11}^{\ell} \left( u_{,rr}^{\ell} + r^{-1} u_{,r}^{\ell} - r^{-2} u^{\ell} \right) + c_{44}^{\ell} u_{,zz}^{\ell} + \left( c_{44}^{\ell} + c_{13}^{\ell} \right) w_{,rz}^{\ell} + \left( e_{31}^{\ell} + e_{15}^{\ell} \right) \phi_{,rz}^{\ell} &= \rho^{\ell} u_{,tt}^{\ell}, \\ \left( c_{44}^{\ell} + c_{13}^{\ell} \right) \left( u_{,rz}^{\ell} + r^{-1} u_{,z}^{\ell} \right) + c_{44}^{\ell} \left( w_{,rr}^{\ell} + r^{-1} w_{,r}^{\ell} \right) + c_{33}^{\ell} w_{,zz}^{\ell} + e_{15}^{\ell} \left( \phi_{,rr}^{\ell} + r^{-1} \phi_{,\theta\theta}^{\ell} \right) + e_{33}^{\ell} \phi_{,zz}^{\ell} &= \rho^{\ell} w_{,tt}^{\ell}, \\ \left( e_{31}^{\ell} + e_{15}^{\ell} \right) \left( u_{,rz}^{\ell} + r^{-1} u_{,z}^{\ell} \right) + e_{15}^{\ell} \left( w_{,rr}^{\ell} + r^{-1} w_{,r}^{\ell} \right) + e_{33}^{\ell} w_{,zz}^{\ell} - \varepsilon_{11}^{\ell} \left( \phi_{,rr}^{\ell} + r^{-1} \phi_{,r}^{\ell} \right) - \varepsilon_{33}^{\ell} \phi_{,zz}^{\ell} &= 0. \end{aligned} \quad (2.1)$$

Here  $u^{\ell}$ ,  $w^{\ell}$  are the displacement components along  $r$ ,  $z$  directions;  $\phi^{\ell}$  the potentials and  $c_{ij}^{\ell}$ : elastic constants,  $e_{ij}^{\ell}$ : piezoelectric constants,  $\varepsilon_{ij}^{\ell}$ : dielectric constants, and  $\rho^{\ell}$ : density of the materials.

The comma followed by superscripts denotes the partial differentiation with respect to those variables and  $t$  is the time.

The solution of (2.1) is taken in the form:

$$\begin{aligned} u^{\ell} &= u_r^{\ell} \exp i(kz + pt), \\ w^{\ell} &= \left( \frac{i}{h} \right) w^{\ell} \exp i(kz + pt), \\ \phi^{\ell} &= i \left( \frac{c_{44}^{\ell}}{h e_{33}^{\ell}} \right) \phi^{\ell} \exp i(kz + pt), \end{aligned} \quad (2.2)$$

where  $p$  is the angular frequency,  $k$  wave number, and “ $h$ ” is the inner radius of the cylinder.

Substituting (2.2) along with the dimensionless variables  $x = r/h$  and  $\varepsilon = kh$  ( $k = 2\pi/\text{wave length}$ ) in (2.1) yields the following equation for the inner and outer cylinder.

$$\begin{vmatrix} \bar{c}_{11}^\ell \nabla^2 + F_1^\ell & -F_2^\ell & -F_3^\ell \\ F_2^\ell \nabla^2 & \bar{c}_{44}^\ell \nabla^2 + F_4^\ell & (\bar{e}_{15}^\ell \nabla^2 - F_5^\ell) \bar{c}_{44}^\ell \\ F_3^\ell \nabla^2 & \bar{e}_{15}^\ell \nabla^2 - F_5^\ell & -(k_{13}^{-2})^\ell \nabla^2 + F_6^\ell \end{vmatrix} (u^\ell, w^\ell, \phi^\ell) = 0, \quad (2.3)$$

where

$$\begin{aligned} \bar{c}_{ij}^\ell &= \frac{c_{ij}^\ell}{c_{44}^1}, & \bar{e}_{ij}^\ell &= \frac{e_{ij}^\ell}{e_{33}^\ell}, \\ (k_{13}^{-2})^\ell &= \frac{(e_{33}^\ell)^2}{(c_{44}^\ell e_{11}^\ell)}, & c^2 &= \frac{\rho^1 \rho^2}{c_{44}^\ell}, & \nabla^2 &= \frac{\partial^2}{\partial x^2} + \frac{1}{x} \frac{\partial}{\partial x}, \\ F_1^\ell &= \frac{\rho^\ell}{\rho^1} (ch)^2 - \varepsilon^2 \bar{c}_{44}^\ell, & F_2^\ell &= \varepsilon (\bar{c}_{44}^\ell + \bar{c}_{13}^\ell), \\ F_3^\ell &= \varepsilon (\bar{e}_{31}^\ell + \bar{e}_{15}^\ell), & F_4^\ell &= \frac{\rho^\ell}{\rho^1} (ch)^2 - (\bar{c}_{33}^\ell \varepsilon^2), \\ F_5^\ell &= \varepsilon^2, & F_6^\ell &= (k_{33}^{-2})^\ell \varepsilon^2. \end{aligned} \quad (2.4)$$

Equation (2.3) can be expressed as

$$(\nabla^6 + P^\ell \nabla^4 + Q^\ell \nabla^2 + R^\ell) (u^\ell, w^\ell, \phi^\ell) = 0, \quad (2.5)$$

where

$$\begin{aligned} P^\ell &= \bar{c}_{11}^\ell \left[ (k_{13}^{-2})^\ell F_4^\ell - F_6^\ell - 2F_5^\ell \bar{e}_{15}^\ell \right] + F_1^\ell \left[ (k_{13}^{-2})^\ell + (\bar{e}_{15}^\ell)^2 \right] \\ &+ F_2^\ell \left[ (k_{13}^{-2})^\ell F_2^\ell + \bar{e}_{15}^\ell F_3^\ell \right] + \frac{F_3^\ell (\bar{e}_{15}^\ell F_2^\ell - F_3^\ell)}{\bar{c}_{11}^\ell \left[ (k_{13}^{-2})^\ell + (\bar{e}_{15}^\ell)^2 \right]}, \end{aligned}$$

$$\begin{aligned}
Q^\ell &= \left( \bar{c}_{11}^\ell (F_5^\ell)^2 - F_4^\ell F_6^\ell \right) + F_1^\ell \left[ (k_{13}^{-2})^\ell F_4^\ell - F_6^\ell - 2F_5^\ell \bar{e}_{15}^\ell \right] \\
&\quad - F_2^\ell (F_2^\ell F_6^\ell + F_3^\ell F_5^\ell) - \frac{F_3^\ell (F_2^\ell F_5^\ell + F_3^\ell F_4^\ell)}{\bar{c}_{11}^\ell \left[ (k_{13}^{-2})^\ell + (\bar{e}_{15}^\ell)^2 \right]}, \\
R^\ell &= \frac{F_1^\ell \left[ (F_5^\ell)^2 - F_4^\ell F_6^\ell \right]}{\bar{c}_{11}^\ell \left[ (k_{13}^{-2})^\ell + (\bar{e}_{15}^\ell)^2 \right]}.
\end{aligned} \tag{2.6}$$

The solutions of (2.5)

$$\begin{aligned}
u^\ell &= \sum_{j=1}^3 \left[ A_j^\ell J_n(\alpha_j^\ell x) + B_j^\ell y_n(\alpha_j^\ell x) \right], \\
w^\ell &= \sum_{j=1}^3 d_j^\ell \left[ A_j^\ell J_n(\alpha_j^\ell x) + B_j^\ell y_n(\alpha_j^\ell x) \right], \\
\phi^\ell &= \sum_{j=1}^3 e_j^\ell \left[ A_j^\ell J_n(\alpha_j^\ell x) + B_j^\ell y_n(\alpha_j^\ell x) \right].
\end{aligned} \tag{2.7}$$

Here  $(\alpha_j^\ell)^2$  are the nonzero roots of

$$(\alpha_j^\ell)^6 - P^\ell (\alpha_j^\ell)^4 + Q^\ell (\alpha_j^\ell)^2 - R^\ell = 0. \tag{2.8}$$

The arbitrary constants  $d_j^\ell$  and  $e_j^\ell$  are given by

$$F_2^\ell d_j^\ell + F_3^\ell e_j^\ell = F_1^\ell - c_{11}^{-1} (\alpha_j^\ell)^2 - \left[ e_{15}^\ell (\alpha_j^\ell)^2 + F_5^\ell \right] d_j^\ell + \left[ k_{13}^{-2} (\alpha_j^\ell)^2 + F_6^\ell \right] e_j^\ell = F_3^\ell (\alpha_j^\ell)^2. \tag{2.9}$$

For isotropic LEMV materials, the governing equations are

$$\mu^\ell \nabla^2 \bar{u}^\ell + (\lambda^\ell + \mu^\ell) \nabla \nabla \cdot \bar{u}^\ell = \rho^\ell \bar{u}_{,tt}^\ell, \tag{2.10}$$

where

$\bar{u}^\ell$  is the displacement vector,

$\lambda^\ell = c_{12}$ ,  $\mu^\ell = (c_{11} - c_{12})/2$  are Lamé's constants,

$\rho^\ell$  is the mass density and  $t$  is the time.

The solution of (2.10) is taken as

$$\begin{aligned} u^\ell &= \left(u_{,r}^\ell\right) \exp i(kz + pt), \\ w^\ell &= \left(\frac{i}{h}\right) w^\ell \exp i(kz + pt). \end{aligned} \quad (2.11)$$

Using the solution in (2.11) and the dimensionless variables  $x$  and  $\epsilon$ , equation (2.10) can be simplified as

$$\left| \begin{array}{cc} \left(\bar{\lambda}^\ell + 2\bar{\mu}^\ell\right) \nabla^2 + F_1^\ell & -F_2^\ell \\ F_2^\ell \nabla^2 & \bar{\mu}^\ell \nabla^2 + F_4^\ell \end{array} \right| \left(u^\ell, w^\ell\right) = 0, \quad (2.12)$$

where

$$\begin{aligned} \bar{\lambda}^\ell &= \frac{\lambda^\ell}{c_{44}^1}, & \bar{\mu}^\ell &= \frac{\mu^\ell}{c_{44}^1}, \\ F_1^\ell &= \left(\frac{\rho^\ell}{\rho^1}\right) (ch)^2 - \bar{\mu}^\ell \epsilon^2, \\ F_2^\ell &= \left(\bar{\lambda}^\ell + \bar{\mu}^\ell\right) \epsilon, & F_4^\ell &= \left(\frac{\rho^\ell}{\rho^1}\right) (ch)^2 - \left(\bar{\lambda}^\ell + 2\bar{\mu}^\ell\right) \epsilon^2. \end{aligned} \quad (2.13)$$

The equation (2.12) can be written as

$$\left(\nabla^4 + P^\ell \nabla^2 + Q^\ell\right) \left(u^\ell, w^\ell\right) = 0, \quad (2.14)$$

where

$$\begin{aligned} P^\ell &= \frac{\left[\left(\bar{\lambda}^\ell + 2\bar{\mu}^\ell\right) F_4^\ell + \bar{\mu}^\ell F_1^\ell + \left(F_2^\ell\right)^2\right]}{\left(\bar{\lambda}^\ell + 2\bar{\mu}^\ell\right) \bar{\mu}^\ell}, \\ Q^\ell &= \frac{\left[F_1^\ell F_4^\ell\right]}{\left(\bar{\lambda}^\ell + 2\bar{\mu}^\ell\right) \bar{\mu}^\ell}. \end{aligned} \quad (2.15)$$

The solutions of (2.14) are

$$\begin{aligned}
 u^\ell &= \sum_{j=1}^3 \left[ A_j^\ell J_n(\alpha_j^\ell x) + B_j^\ell y_n(\alpha_j^\ell x) \right], \\
 w^\ell &= \sum_{j=1}^3 d_j^\ell \left[ A_j^\ell J_n(\alpha_j^\ell x) + B_j^\ell y_n(\alpha_j^\ell x) \right],
 \end{aligned} \tag{2.16}$$

where  $(\alpha_j^\ell)^2$  is the nonzero roots of

$$(\alpha_j^\ell)^4 + P^\ell (\alpha_j^\ell)^2 - Q^\ell = 0. \tag{2.17}$$

And the arbitrary constants  $d_j^\ell$  are obtained from

$$d_j^\ell = \frac{\left[ -(\bar{\lambda}^\ell + 2\bar{\mu}^\ell) (\alpha_j^\ell)^2 + F_1^\ell \right]}{F_2^\ell}. \tag{2.18}$$

### 3. Boundary Interface Conditions and Frequency Equations

The frequency equations can be obtained by using the following boundary and interface conditions.

- (i) On the traction free inner outer surface  $T_{rr}^\ell = T_{rz}^\ell = \phi^\ell = 0$  with  $\ell = 1, 5$ .
- (ii) At the interface between (outer and middle and middle and inner) cylinders  $T_{rr}^\ell = T_{rr}^{\ell+1}, T_{rz}^\ell = T_{rz}^{\ell+1}, u^\ell = u^{\ell+1}, w^\ell = w^{\ell+1}, \phi^\ell = 0$ , with  $\ell = 1, 2, 3, 4, 5$ .

The frequency equation is obtained as a  $26 \times 26$  determinant equation by substituting the solutions in the boundary interface conditions. It is written as

$$|(D_{i,j})| = 0, \quad (i, j = 1, 2, \dots, 26), \tag{3.1}$$

and the nonzero elements by varying  $j$  from 1 to 3 and  $k$  varies from 1 to 2 are

$$\begin{aligned}
 D(1, j) &= \left[ 2\mu \left( \frac{\alpha_j}{x_0} \right) J_{n+1}(\alpha_j x_0) + [ -(\bar{\lambda} + 2\mu)(\alpha_j)\beta e_i - \bar{\lambda}\epsilon d_j ] \right. \\
 &\quad \left. + 2n(n-1) \left( \frac{\mu}{x_0} \right) J_n(\alpha_j x_0) \right], \\
 D(2, j) &= (\epsilon + d_j + \bar{e}_{15}e_j)(\alpha_j) J_{n+1}(\alpha_j x_0), \\
 D(3, j) &= e_j J_{n+1}(\alpha_j x_0), \\
 \text{At } x_1 &= \frac{h_1}{h}, \\
 D(4, j) &= \left[ 2\mu \left( \frac{\alpha_j^1}{x_1} \right) J_{n+1}(\alpha_j^1 x_1) \right. \\
 &\quad \left. + [ -(\bar{\lambda} + 2\mu)(\alpha_j^1) \beta^1 e_j^1 - \bar{\lambda}\epsilon e_j^1 ] + 2n(n-1) \left( \frac{\mu}{x_1^2} \right) J_n(\alpha_j^1 x_1) \right], \\
 D(4, k+6) &= - \left[ 2\mu \left( \frac{\alpha_j^2}{x_1} \right) J_{n+1}(\alpha_j^2 x_1) + [ -(\bar{\lambda} + 2\mu)(\alpha_j^2) \beta^2 e_j^2 - \bar{\lambda}\epsilon e_j^2 ] \right. \\
 &\quad \left. + 2n(n-1) \left( \frac{\mu}{x_1^2} \right) J_n(\alpha_j^2 x_1) \right], \\
 D(5, j) &= (\epsilon + d_j^2 + \bar{e}_{15}^2 e_j^2)(\alpha_j^2) J_{n+1}(\alpha_j^2 x_1), \\
 D(5, k+6) &= -\mu(-(\epsilon + d_j^1)) \alpha_j^1 J_{n+1}(\alpha_j^1 x_1), \\
 D(6, j) &= -(\alpha_j^1) J_{n+1}(\alpha_j^1 x_1), \\
 D(6, k+6) &= -(\alpha_j) J_{n+1}(\alpha_j x_1), \\
 D(7, j) &= d_j^1 J_{n+1}(\alpha_j x_1), \\
 D(7, k+6) &= -d_j J_{n+1}(\alpha_j x_1), \\
 D(8, j) &= e_j^1 J_{n+1}(\alpha_j^1 x_1),
 \end{aligned}
 \tag{3.2}$$

and the other elements  $D(i, j+3)$  ( $i = 1, 2, 3, \dots, 8; j = 1, 2, 3$ ) and  $D(i, k+8)$  ( $i = 4, 5, 6, 7; k = 1, 2$ ) are obtained by replacing  $J_n$  and  $J_{n+1}$  by  $Y_n$  and  $Y_{n+1}$  in the above elements.

At the inter face  $x = x_2$ , non zero elements along the following rows  $D(i, j)$ , ( $i = 9, 10, 11, 12, 13$ ) ( $j = 7, 8, 9, \dots, 16$ ) are obtained on replacing  $x_1$  by  $x_2$  and super script 1 by 2 in order. The non-zero elements at the second interface are,  $D(i, j)$ , ( $i = 14, 15, 16, 17, 18$ ) ( $j = 11, 12, 13, \dots, 20$ ) can be obtained by assigning  $x_3$  for  $x_4$  and superscript 4 for 3. The non zero

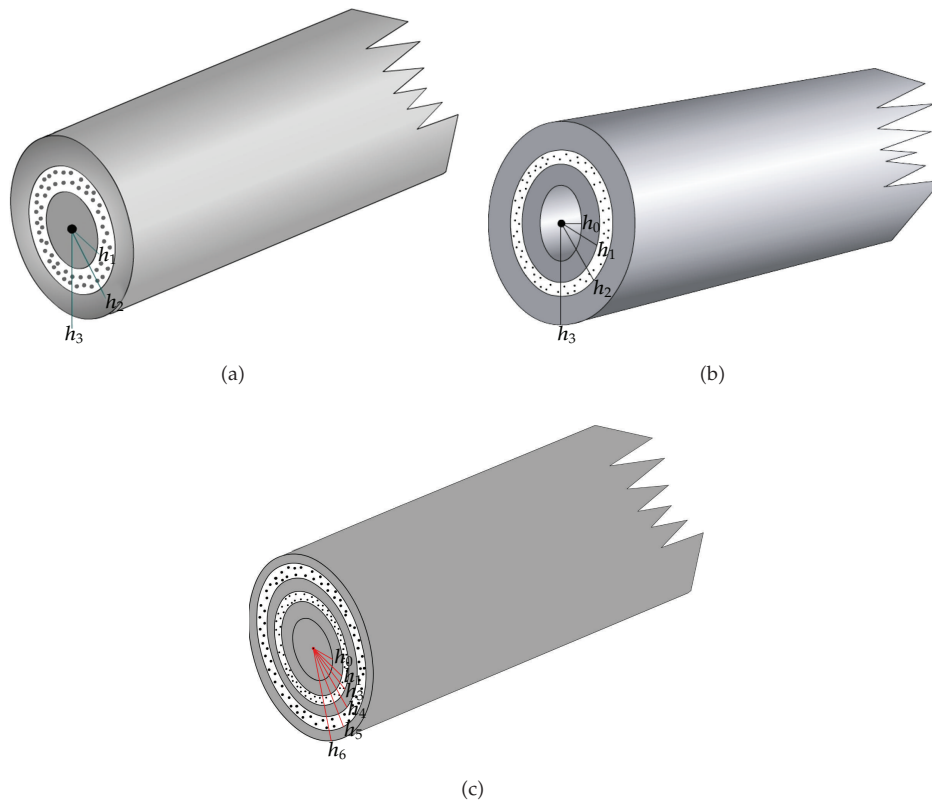

**Figure 1:** (a) A three-layered piezocomposite solid cylinder. (b) A three-layered piezocomposite hollow cylinder. (c) a Five-Layered Piezocomposite Solid Cylinder.

elements at the third layer are,  $D(k, j)$ , ( $i = 19, 20, 21, 22, 23$ ) and  $j = 17, 18, 19, \dots, 26$ ) are obtained on replacing  $x_4$  by  $x_5$ . Similarly, at the outer surface  $x = x_5$ , the nonzero elements  $D(i, j)$ , ( $i = 24, 25, 26$ ) ( $j = 21, 22, 23, 24, 25, 26$ ) can be had from the nonzero elements of the first four rows by assigning  $x_5$  for  $x_0$  and superscript 2 for 1. The frequency equations derived above are valid for different inner solid, middle and outer hollow materials of 6 mm class and arbitrary thickness of layers.

#### 4. Piezocomposite Cylindrical Models

A three-layered Piezocomposite solid/hollow cylinder made of Cermaic-1/Adhesive/Ceramic-2 and a five-layered Piezocomposite solid cylinder made of Cermaic-1/Adhesive1/Ceramic-2/Adhesive2/Ceramic-3 considered for deriving frequency equations in various types of vibrations (Figure 1).

#### 5. Numerical Results

The frequency equation (3.1) and corresponding equation are numerically evaluated for PZT4/CFRP/PZT4/CFRP/PZT4. Material Constants of CFRP bonding layer are taken from



**Table 1:** Different value of complex frequencies for real wave numbers in the first axial mode of piezocomposite Hollow cylinder.

Wave no ( $\epsilon$ )	Frequencies		
	With middle core LEMV ( $N = 0.33$ ) [24]	With middle core CFRP-3 layer [27]	With middle core LEMV-5 layer
0.1	$0.3269 + i 0.0622$	$0.2779 + i 0.0022$	$0.2081 + i 0.0000$
0.4	$0.4949 + i 0.1394$	$0.3515 + i 0.2519$	$0.4120 + i 0.0001$
0.8	$0.6768 + i 0.0011$	$0.7996 + i 0.0000$	$0.5230 + i 0.0000$
1.2	$1.1933 + i 0.0023$	$1.0986 + i 0.0001$	$0.8310 + i 0.0000$
1.6	$1.4775 + i 0.1255$	$1.3755 + i 0.0001$	$1.0000 + i 0.0000$
2.0	$1.6034 + i 0.2067$	$1.6998 + i 0.0016$	$1.2380 + i 0.0000$
2.4	$1.8824 + i 0.4089$	$2.0231 + i 0.0050$	$1.4000 + i 0.0000$
2.8	$2.0968 + i 0.0000$	$2.8000 + i 0.0000$	$1.6120 + i 0.0000$
3.0	$2.2816 + i 0.9168$	$3.0000 + i 0.0000$	$1.8000 + i 0.0000$

**Table 2:** Different values of complex frequencies for real wave numbers in the second axial mode of piezocomposite Hollow cylinder.

Wave no ( $\epsilon$ )	Frequencies		
	With middle core LEMV ( $N = 0.33$ ) [24]	With middle core CFRP-3 layer [4]	With middle core CFRP-5 layer
0.1	$0.3865 + i 0.0755$	$0.7015 + i 0.2708$	$0.3000 + i 0.0000$
0.4	$0.5392 + i 0.1051$	$0.7581 + i 0.0019$	$0.5000 + i 0.0000$
0.8	$0.7020 + i 0.0289$	$0.8230 + i 0.0083$	$0.6120 + i 0.0001$
1.2	$1.2581 + i 0.0000$	$1.1999 + i 0.0000$	$0.0728 + i 0.0004$
1.6	$1.4854 + i 0.0006$	$1.5999 + i 0.0000$	$0.8250 + i 0.0000$
2.0	$1.6464 + i 0.0015$	$1.9996 + i 0.0000$	$0.9280 + i 0.0000$
2.4	$2.0180 + i 0.5477$	$2.3986 + i 0.0002$	$1.1000 + i 0.0000$
2.8	$2.1510 + i 0.7166$	$2.7998 + i 0.0000$	$1.3000 + i 0.0001$
3.0	$2.5692 + i 0.0038$	$3.0524 + i 0.1521$	$1.4000 + i 0.0007$

Ashby and Jones [28]. The elastic piezoelectric and dielectric constants of PZT4 are taken from Brelincourt et al. [29]. The roots of the frequency equations are calculated using Muller's method. The complex frequencies for the axisymmetric waves in the first and second modes are given in Tables 1 and 2. The attenuation in the case of piezocomposite with LEMV (5-layer Model) as the middle core is more when compared to CFRP (3 layer model) [27]. Piezocomposite with LEMV (when  $N = 0.33$ ) [24] as core material. The dispersion curves for the real part of frequency against the dimensionless wave numbers are plotted for the first and second axisymmetric mode in Figure 2. The bold, discontinuous, and dotted lines indicate the dispersion curves in the axisymmetric vibrations of the piezolaminated-LEMV (5-layer model), piezolaminated-CFRP (3-Layer Model) [27] and piezolaminated-LEMV (with  $N = 0.33$ ) [24] cylinders.

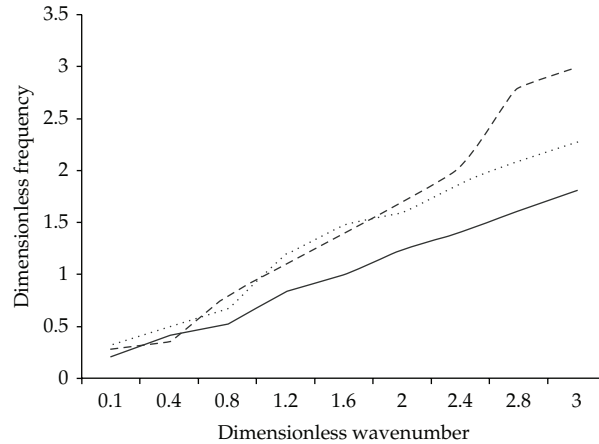

(a)

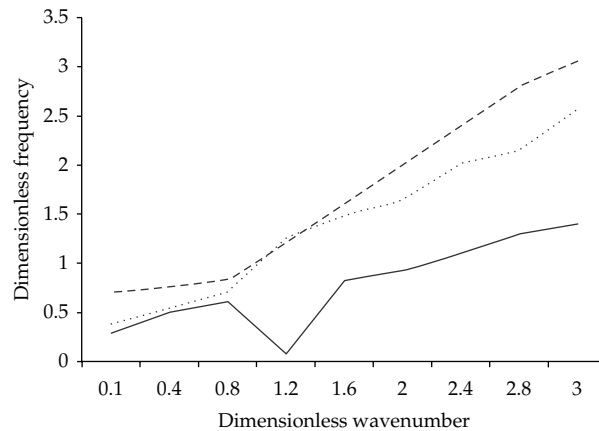

(b)

**Figure 2:** (a) Comparison of dispersion curves of piezocomposite hollow cylinders PZT4/LEMV/PZT4/LEMV/PZT4 (Bold line), PZT4/CFRP/PZT4 (Discontinuous line), and PZT4/LEMV ( $N = 0.33$ )/PZT4 (Dotted line) in the first axial mode. (b) Comparison of dispersion curves of piezocomposite hollow cylinders PZT4/LEMV/PZT4/LEMV/PZT4 (Bold line), PZT4/CFRP/PZT4 (Discontinuous line) and PZT4/LEMV ( $N = 0.33$ )/PZT4 (Dotted line) in the second axial mode.

## 6. Conclusion

The frequency equation for free axisymmetric vibration of piezolaminated multilayer hollow cylinder with isotropic CFRP bonding layers is derived. The numerical results are carried out for PZT4/LEMV/PZT4/LEMV/PZT4 and are compared with piezolaminated-CFRP multilayer (3-layer) [27] hollow cylinder and piezolaminated-LEMV (3-layer) (With  $N = 0.33$ ) [24] cylinder. It is observed from the numerical data that the attenuation effect in the present model with LEMV bonding layers is low when compared to the piezolaminated-LEMV (3-layer) (With  $N = 0.33$ ) [24] cylinder and piezolaminated-CFRP multilayer (3-layer) [27] hollow cylinder. Also the damping effect in the present five-layered model is low when compared with three-layered CFRP hollow Piezocomposite models.

## References

- [1] D. P. Skinner, R. E. Newnham, and L. E. Cross, "Flexible composite transducers," *Materials Research Bulletin*, vol. 13, no. 6, pp. 599–607, 1978.
- [2] W. A. Smith, "Role of piezocomposites in ultrasonic transducers," in *Proceedings of the IEEE Ultrasonics Symposium*, pp. 755–766, October 1989.
- [3] W. A. Smith, "Tailoring the composite piezoelectric materials for medical ultrasonic transducers," in *Proceedings of the IEEE Ultrasonics Symposium*, pp. 642–647.
- [4] R. E. Newnham, D. P. Skinner, and L. E. Cross, "Connectivity and piezoelectric-pyroelectric composites," *Materials Research Bulletin*, vol. 13, no. 5, pp. 525–536, 1978.
- [5] J. R. Giniewicz, R. E. Newnham, A. Safari, and D. Moffatt, "(Pb, Bi)(Ti, Fe, Mn)O<sub>3</sub>/polymer 0–3 composites for hydrophone applications," *Ferroelectrics*, vol. 103, no. 3, pp. 1449–1467, 1998.
- [6] L. Bowen, R. Gentilman, D. Fiore et al., "Design, fabrication, and properties of sonopanel<sup>TM</sup> 1–3 piezocomposite transducers," *Ferroelectrics*, vol. 187, no. 1–4, pp. 109–120, 1996.
- [7] Q. M. Zhang, J. Chen, H. Wang, J. Zhao, L. E. Cross, and M. C. Trottier, "New transverse piezoelectric mode 2-2 piezocomposite for underwater transducer applications," *IEEE Transactions on Ultrasonics, Ferroelectrics, and Frequency Control*, vol. 42, no. 4, pp. 774–781, 1995.
- [8] S. Marselli, V. Pavia, C. Galassi, E. Roncari, F. Craciun, and G. Guidarelli, "Porous piezoelectric ceramic hydrophone," *Journal of the Acoustical Society of America*, vol. 106, no. 2, pp. 733–738, 1999.
- [9] W. A. Smith and B. A. Auld, "Modeling 1–3 composite piezoelectrics: thickness-mode oscillations," *IEEE Transactions on Ultrasonics, Ferroelectrics, and Frequency Control*, vol. 38, no. 1, pp. 40–47, 1991.
- [10] G. Hayward and J. A. Hossack, "Finite element analysis of 1–3 composite piezoelectric transducers," *IEEE Transactions on Ultrasonics, Ferroelectrics and Frequency Control*, vol. 38, pp. 618–629, 1991.
- [11] H. Kara, A. Perry, R. Stevens, and C. R. Bowen, "Interpenetrating PZT/polymer composites for hydrophones: models and experiments," *Ferroelectrics*, vol. 265, no. 1, pp. 317–332, 2002.
- [12] T. Arai, K. Ayusawa, H. Sato, T. Miyata, K. Kawamura, and K. Kobayashi, "Properties of hydrophone with porous piezoelectric ceramics," *Japanese Journal of Applied Physics, Part 1*, vol. 30, no. 9, pp. 2253–2255, 1991.
- [13] K. Ina, T. Mano, S. Omura, and K. Nagata, "Hydrophone sensitivity of porous Pb(Zr, Ti)O<sub>3</sub> ceramics," *Japanese Journal of Applied Physics, Part 1*, vol. 33, no. 9, pp. 5381–5384, 1994.
- [14] P. Guillaussier, C. Audoly, and D. Boucher, "Porous lead zirconate titanate ceramics for hydrophones," vol. 187, no. 1–4, pp. 121–128.
- [15] H. Kara, R. Ramesh, R. Stevens, and C. R. Bowen, "Porous PZT ceramics for receiving transducers," *IEEE Transactions on Ultrasonics, Ferroelectrics, and Frequency Control*, vol. 50, no. 3, pp. 289–296, 2003.
- [16] T. E. Gómez, F. Montero De Espinosa, F. Levassort et al., "Ceramic powder-polymer piezocomposites for electroacoustic transduction: modeling and design," *Ultrasonics*, vol. 36, no. 9, pp. 907–923, 1998.
- [17] K. Uchino, "Electrostrictive actuators: materials and applications," *American Ceramic Society Bulletin*, vol. 65, no. 4, pp. 647–652, 1986.
- [18] S. R. Winzer, N. Shankar, and A. P. Ritter, "Designing cofired multilayer electrostrictive actuators for reliability," *Journal of the American Ceramic Society*, vol. 72, no. 12, pp. 2246–2257, 1989.
- [19] K. Takagi, H. Sato, and M. Saigo, "Damage detection and gain-scheduled control of CFRP smart board mounting the metal core assisted piezoelectric fiber," in *Smart Structures and Materials 2005: Modeling, Signal Processing, and Control*, vol. 5757, pp. 471–480, San Diego, Calif, USA, March 2005.
- [20] T. Tanimoto, "Carbon-fiber reinforced plastic passive composite damper by use of piezoelectric polymer/ceramic," *Japanese Journal of Applied Physics, Part 1*, vol. 41, no. 11, pp. 7166–7169, 2002.
- [21] H. S. Paul, "Vibrations of circular cylindrical shells of piezoelectric silver iodide crystals," *Journal of the Acoustical Society of America*, vol. 40, pp. 1077–1080, 1966.
- [22] H. S. Paul and V. K. Nelson, "Axisymmetric vibration of piezoelectric composite cylinders," in *Proceedings of the 3rd international congress on Air and Structure-borne Sound and Vibration*, vol. 1, pp. 137–144, 1994.
- [23] H. S. Paul and V. K. Nelson, "Wave propagation in piezocomposite plates," *Proceedings of the Indian National Science Academy—Part A*, pp. 221–228, 1995.
- [24] H. S. Paul and V. K. Nelson, "Axisymmetric vibration of piezocomposite hollow circular cylinder," *Acta Mechanica*, vol. 116, pp. 213–222, 1996.
- [25] H. S. Paul and V. K. Nelson, "Flexural vibration of piezoelectric composite hollow cylinder," *Journal of the Acoustical Society of America*, vol. 99, no. 1, pp. 309–313, 1996.

- [26] B. K. Sinha, T. J. Plona, S. Kostek, and S.-K. Chang, "Axisymmetric wave propagation in fluid-loaded cylindrical shells. I: theory," *Journal of the Acoustical Society of America*, vol. 92, no. 2, pp. 1132–1143, 1992.
- [27] V. K. Nelson and E. S. Nehru, "Flexural vibration of piezolaminated multilayer solid cylinder," *International Journal of Computational and Applied Mathematics*, vol. 2, no. 2, pp. 75–85, 2007.
- [28] M. F. Ashby and D. R. H. Jones, *Engineering Materials 2*, Pergamon Press, London, UK, 1986.
- [29] D. A. Brellincourt, D. R. Curran, and H. Jafee, *Physical Acoustics*, vol. 1, Academic Press, New York, NY, USA, 1964.



# Hindawi

Submit your manuscripts at  
<http://www.hindawi.com>

